

**Eagle Eye Battery Room
Venting System 115V AC**



Executive Summary

Eagle Eye's hydrogen gas detector and forced ventilation fan system designed for use in battery charging rooms and other areas where Hydrogen may be present. The system consists of a minimum of two parts, a hydrogen gas detector with relay contacts that mounts in the highest part of the room and a large vent fan enclosure mounted through the outside wall. The system is NFPA compliant. The system has four fans factory rated at 850 CFM each. This conforms to N+ 1 for 2550 CFM. The vent is equipped with a Positive Airflow Shut Off. These doors can be closed by an external electrical command. They will stop any airflow from passing through the fans. Available power options are 110 V AC, 24 V DC, or minus 48 V direct current. It is fused at 10 amps for -48v. The vents can be daisy chained, more than one vent can be controlled by one gas detector. More than one hydrogen gas detector can activate a vent. The unit usually is set up to exhaust air but can be factory configured to source forced air into a room. These units are designed with flexibility in mind.

Compliance

Properly installed, the system is compliant with The National Electric Code (NEC) Section 480.9 (A) for ventilation of battery rooms. This is also the specified requirement for solar or wind generated power Battery Rooms. It is also compliant with The National Fire Protection Association, NFPA 2 Hydrogen Technology Code, which is more stringent. The minimum system consists of an Hydrogen Gas Detector, and a Battery Room Forced Ventilator with Positive Airflow Shut Off, a remote firefighter's shutdown capability, a backflow damper, and a 2% monitored alarm. This unit complies with NEC 501.125. (B), 501.105 (1)-3 and is designed for use in Class 1 Div. 2 hydrogen containing classified areas.

.The fan unit is compliant with the NFPA Standard on Clean Agent Fire Extinguishing Systems (2001) Section C2.8.2.7.7 and may be used as per Sections 5.3.4, 5.3.6, 7.7.2.4.8, A5.3.6, A8.7.2 and C2.4.3.4

The fan unit is compliant with the NFPA Standard 90A Section 4.2.3, 4.2.3.1, 4.2.3.1.2, 4.2.3.2.2, and 4.2.3.3

All the active component parts on the Eagle Eye Fan Battery Room Exhaust Fan With Positive Airflow Shut Off System that are subject to testing are certified by the Underwriters' Laboratory as follows.

<u>Part Number</u>	<u>Description and Manufacturers Part # - UL number</u>
191200	FAN DC 254X89 48V 690CFM -Orion# OD254AP-48MB - UL E17049
311011	Wire, UL1430 #24 Brown
311019	Wire, UL1430 #24 White
311060	Wire, UL1430#18 Black
311066	Wire, UL1430 #18 Blue
311072	Wire, UL1430 #16 Red
311057	Wire, UL1430 #20 Violet
151259	Receptacle, Mplex, 9 pin – Molex # 538-19-09-1099 - UL E29179
150110	Pin & Socket Connectors 9 CIRCUIT HOUSING- Molex# 15-31-1096 - UL E29179
131005	CALRAD Magnetic Switch #40-660 - UL 634
131004	DELTROL TUBULAR FRAME Solenoid, 24V MED 16 X 2.000 – UL E57982 & E74443
130003	Power Relay, Compact PC Board, NAIS# JW1FSN-DC48V – UL E43028
<u>Additional parts found only on the Eagle Eye Hydrogen Gas Detector</u>	
130007	Power Relay, Compact PC Board, NAIS# JW1FSN-DC12V– UL E43028
140014	Flyback Transformer, Premier Magnetics # PNY-24004 – UL E162344
150058	Phoenix Contact # 1715734

Features of the Eagle Eye Hydrogen Gas Detector



Should the concentration of hydrogen gas in the air surrounding the sensor reach 1% by volume (10,000 ppm), the "1% Caution" yellow LED will light and the 1% internal relay will close. Should the hydrogen gas concentration reach 2% by volume (20,000 ppm), the "2% Warning" red LED will flash and an 80 db alarm will sound; the 1% relay will remain closed and, if a Dual-Relay model, the 2% internal relay will close. Either relay can activate a remote exhaust fan and/or alarm.

Dimensions: Height 7 " (17.8 cm.)
Width 4-3/4 " (12.0 cm.)
Depth 2-1/2 " (5.5 cm.)

Mounting: Four 3/16 " (4.5 mm.) screws

Power Requirements: 24, 48 volts dc. or 115 VAC as ordered

Relay(s): At 2% SPDT.
At 1% SPDT

Operating Temperature: 14 to 104 degrees F (-10 to 40 degrees C)

H2 Battery Room Forced Ventilator with Positive Airflow Shut Off



If the room were to experience the release of hydrogen gas, the hydrogen gas detector would turn on the fans when the atmosphere reached 1% hydrogen. It would sound the alarm at 2% hydrogen. Both of these would have been well before the lean mixture of hydrogen could ignite. During this period of time, we want the fans operating to vent the hydrogen gas.



In operating mode

If a thermal event occurs and proceeds into a conflagration, we want the fans off and the Positive Airflow Shut Off closed. This will prevent the air passage through the fan from acting as a chimney and drawing oxygen rich fresh air into the burning room.



After Positive airflow shut off

When the Positive Airflow Shut Off is activated by the firefighter pulling the Emergency Fan Stop switch, air pressure from the fans, and gravity, and a spring, will act to close the positive shut off doors and keep them closed. A red LED at the junction box will come on. The Positive Airflow Shut Off must be manually reset to prevent inadvertent reset in an actual shut off event.

To reset, Open the Positive Shut off System switch. Remove the front screen. Lift the doors up. Reset the latches. Then close the front screen.



Positive shut off doors closed

Latch

Doors reset

Louvered dampers on the exterior of the unit will prevent domestic air from escaping from the room during non-operation. The fans will blow these louvered dampers open and gravity will close them. These louvered dampers do add a restriction to the airflow and will decrease the CFM somewhat.



Louver open



Louver closed

Installation

The battery room ventilator unit comes as three separate pieces. The unit that is in the battery room, is 24" x 24" square. To accommodate airflow, and to service the unit a clearance of 4 feet is recommended from the wall in front of the unit. There is a flange that is factory adjustable but normally is located 6 inches from the back of the unit. If the wall is made in the concrete block or a concrete wall, the unit is attached to the wall by others using normal fasteners. The second part of the unit consists of a louvered damper and third is a jack which provides environmental protection for the outside of the unit.

The damper- jack is affixed to the outside wall with normal fasteners by others. It measures 24 inches square and needs an outside clearance of 30 inches. A one inch flange is provided to attach the unit and is in addition the listed dimensions.



There are two different styles of wall jack available. There is a standard wall jack, and an optional 90° wall jack where there is a high probability of heavy mechanical damage to the outside wall of the building.

If the unit is an Exhaust Fan the louvers must be turned to let air out. If the unit is a Supply Fan the louvers must be turned to let air into the room. It can be positioned either way. So, the installer must understand the airflow direction. Fan Units come from the factory with the fans mounted in the direction needed for proper airflow. Louvers used with Supply Fans have a spacer to provide room for louver movement. The spacer, louver and rain hood come from the factory as an assembly. It is ready for installation. The louver is the only installation difference.



Louver set up for Exhaust Fan



Louver set up for Supply Fan

A Control Box is provided to connect Power, Return, Signaling from the HGD Sensor, Dry Contact inputs to activate the Positive Airflow Shut Off, and Case Ground. This box may be factory relocated to either side, or the bottom of the unit.

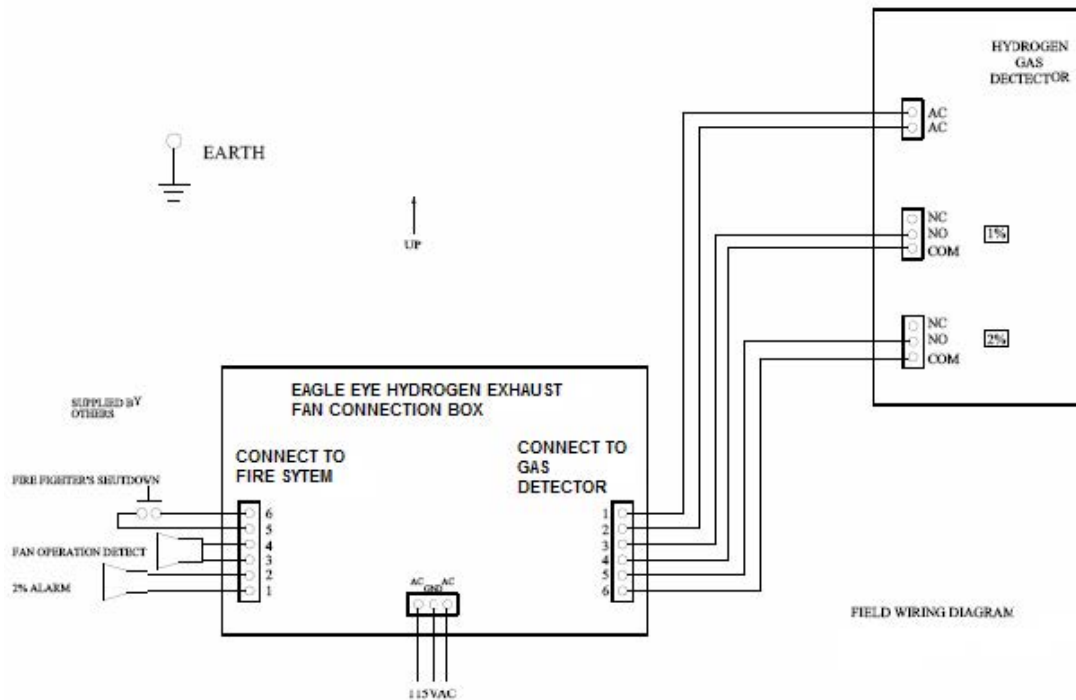

Electrical Installation

Test

After the system is powered up it should be tested. Push the test button on the first hydrogen gas detector. The system will perform a self-diagnostic, and then turn on the yellow LED. At this time, the fans should also activate and the fan operation detect relay, if installed, will close. After a few seconds the red LED will be activated. This should also activate the 2% alarm in the emergency control system supplied by others. After you are satisfied with the first hydrogen gas detector, press the test button on each successive hydrogen gas detector in the loop. It is also possible to activate the system by exposing it to butane. Butane is inexpensively available in small butane operated cigarette lighters. Without lighting the cigarette lighter, squirt the gas on the hydrogen gas detector. This should activate the fans and turn on the 2% alarm. Caution: It is sensitive to butane in order to test the sensor. This is no substitute for a butane sensor. If

you wish to test for butane, contact Eagle Eye. Also note this hydrogen gas detector will not false alarm on smoke or carbon monoxide. It tests for hydrogen only.

Test the positive shut down control. The doors will be shipped in the closed position. When you install the fan, reset the doors by lifting them up and latching them in place. Make sure the fan is powered up. Close the positive shut down control contacts by pulling the Firefighter's Emergency Fan Stop. The doors should drop. Reset the Firefighter's Emergency Fan Stop. Reset the doors and close the screen. The unit is now ready for use.