

Technical Specification

LB-400-500kW-COM Automatic Load Bank

1 Foreword

This solution introduces LB-400-500kW-COM Automatic Load Bank and its accessories, including their function, performance, usage, structure, providing users with a high efficient and reliable choice to test generator.

All the pictures quoted in this agreement are for reference only.

2 Testing System

We do not supply testing cable, PC and printer if not specified.



3 Supply List

The following form presents the accessories provided when we make shipment.

Items	Quantity	Remark
LB-400V-500kW-COM Automatic Load Bank	1	
Power Cord	1	3 meters
RS485	1	10 meters
RS485/RS232/USB Converter	1	
Documents accompanied with shipment	Quantity	Remark
Manual	1	
Packing List	1	
Data Managing Software	1	

Eagle Eye Power Solutions LLC

6306 Eastwood Court • Mequon, WI 53092 • 1-414-962-3660

info@eepowersolutions.com • www.eepowersolutions.com

4 Technical Parameter

Technical Parameter	
Rated Voltage & Frequency	400VAC ; 3 phase 4 wire, 50Hz
Max Load Power	510kW at 400V
Load Steps	Resistive Load: 1, 2, 2, 5, 10, 20, 20, 50, 100, 100, 200kW
Power Factor	1
Load Tolerance (each step)	±5%
Load Tolerance (overall)	±3%
Display Meter	Multiple function meter
Fan Control Power	Auxiliary/external power single phase 110V 120V 130V 200V 210V 220V 230V 240V 50/60Hz
Wire Connection	Load bank input——busbar Control power input——3-core socket
Communication Interface	RS485
Insulation	F
Way of Working	Continuous Working
Cooling	Forced air, horizontal air intake and exhaust cooling
Transportation	With lifting eyes and wheel castors
Color	As request
Dimensions	993*1074*1227mm Width*Length*Height
Weight	400kgs
Operating Environment Parameter	
Ambient Temperature	-20°C~+50°C
Using Place	Indoor
Altitude	≤ 2500 meters
Relative Humidity	≤ 95%
Atmospheric Pressure	86~106kPa
Brands of Main Components	
Contactor	Schneider
Fuse	MIRO
PLC	Siemens

Eagle Eye Power Solutions LLC

6306 Eastwood Court • Mequon, WI 53092 • 1-414-962-3660
info@eepowersolutions.com • www.eepowersolutions.com

5 Functions

- 1) 3- line LED multi-function meter can display real-time voltage and current of three phase and each phase, resistive power, power factor, apparent power, frequency and running time of generator set.
- 2) User can pre-set the power then press the master load button.
- 3) Control mode: user can choose local control or intelligent control (through PC with our data management software).
- 4) Control mode interlock: there is switch in control panel to choose control mode, other control mode is invalid if user choose one control mode.

6 Protection

- 1) Have emergency stop button.
- 2) In case of **over-load, over-heat, short circuit**, load bank will automatically remove load and give alarm.
- 3) Fan protection: Load bank could not load before power of fan is on.
- 4) Give alarm when any fan is abnormal or with insufficient air volume.
- 5) Protection button: there are some protection buttons can be switched off when false alarm or for special requirements.

7 Data Processing Software

- 1) Automatic load: User can set several periods of power and duration and in turn of 0%→25%→50%→75%→100% or 110% then →75%→50%→25%→0%.etc to make automatic load testing.
- 2) Can make parallel testing for several units.
- 3) Data can be saved, could display real-time data and history data.
- 4) Charts and graphs can be exported in format of JPG while testing data exported in Excel and Word format, and all can be printed.

Eagle Eye Power Solutions LLC



EAGLE EYE POWER SOLUTIONS



AC400V-100KW Automatic Load Bank [Hebei Kaixiang Electrical Technology Co., Ltd.]

Testing Time: 2022-06-24 16:19:57 Running Duration: 00:11:45 Test Name: T7 Operator: 88

Record No.	Time	L1(V)	L2(V)	L3(V)	I1(A)	I2(A)	I3(A)	P(kW)	Q(kvar)	S(kVA)	PF	F(Hz)
33	2022-06-24 16:20:29	380.8	379.5	384.8	0	0	0	0	0	0	0	50.08
34	2022-06-24 16:20:30	380.8	379.5	384.8	0	0	0	0	0	0	0	50.08
35	2022-06-24 16:20:31	381.8	379.4	384.7	0	0	0	0	0	0	0	50.08
36	2022-06-24 16:20:32	380.9	378.4	383.8	4.5	6.99	4.83	4.53	0.06	4.53	1	50.09
37	2022-06-24 16:20:33	380.7	378.2	383.6	6.93	6.99	6.75	4.53	0.06	4.53	1	50.09
38	2022-06-24 16:20:34	380.4	377.8	383.1	6.93	6.99	6.75	4.53	0.06	4.53	1	50.09
39	2022-06-24 16:20:35	380.6	378.2	383.4	6.93	6.99	6.75	4.53	0.06	4.53	1	50.1
40	2022-06-24 16:20:36	380.7	378.3	383.6	6.93	6.99	6.75	4.53	0.06	4.53	1	50.1
41	2022-06-24 16:20:37	380.7	378.3	383.6	6.93	6.99	6.75	4.53	0.06	4.53	1	50.1
42	2022-06-24 16:20:38	380.5	378	383.1	6.96	6.99	6.75	4.53	0.06	4.53	1	50.1
43	2022-06-24 16:20:39	380.5	378	383.1	6.96	6.99	6.75	4.53	0.06	4.53	1	50.1
44	2022-06-24 16:20:40	380.4	377.9	383	6.93	6.99	6.75	4.53	0.06	4.53	1	50.1
45	2022-06-24 16:20:41	380.5	377.8	382.9	6.93	6.99	6.75	4.53	0.06	4.53	1	50.09
46	2022-06-24 16:20:42	380	377.3	382.3	6.96	6.99	6.75	4.53	0.06	4.53	1	50.09
47	2022-06-24 16:20:43	379.7	377	381.9	6.96	6.99	6.75	4.53	0.06	4.53	1	50.09
48	2022-06-24 16:20:44	380.1	377.1	382.2	6.93	6.99	6.72	4.5	0.06	4.5	1	50.09
49	2022-06-24 16:20:45	378.3	376.7	381	6.93	6.99	6.72	4.5	0.06	4.5	1	50.1
50	2022-06-24 16:20:46	380.2	377.5	382.7	6.9	6.99	6.72	4.53	0.06	4.53	1	50.12
51	2022-06-24 16:20:47	380.8	377.9	383.4	6.93	6.99	6.75	4.53	0.06	4.53	1	50.11
52	2022-06-24 16:20:48	380.1	376.5	382.4	6.93	6.99	6.75	4.53	0.06	4.53	1	50.1

Export excel

Eagle Eye Power Solutions LLC
 6306 Eastwood Court • Mequon, WI 53092 • 1-414-962-3660
info@eepowersolutions.com • www.eepowersolutions.com

8 Pictures

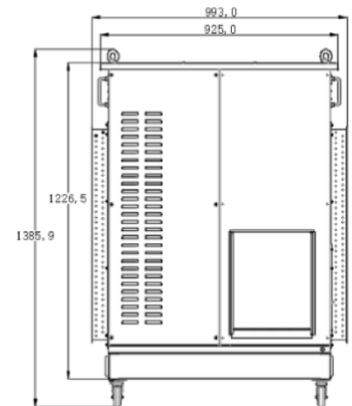
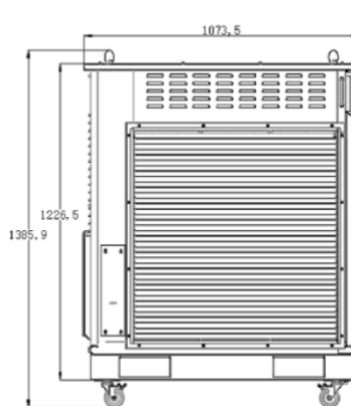
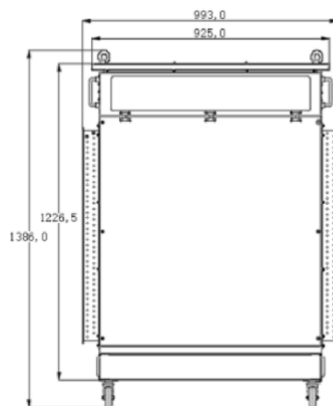
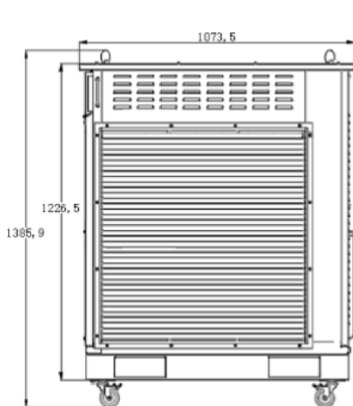
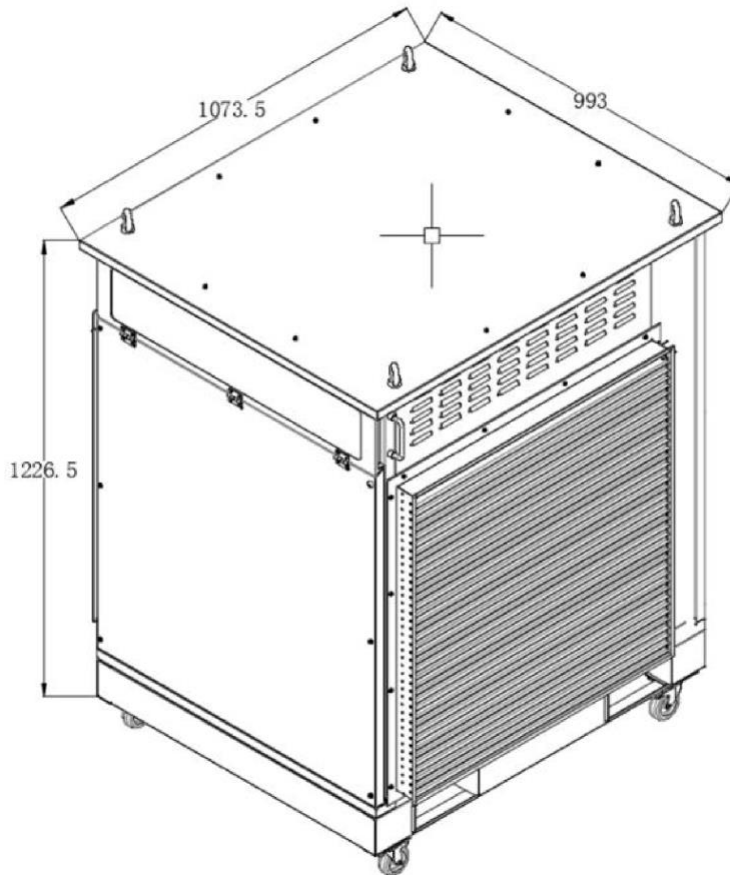

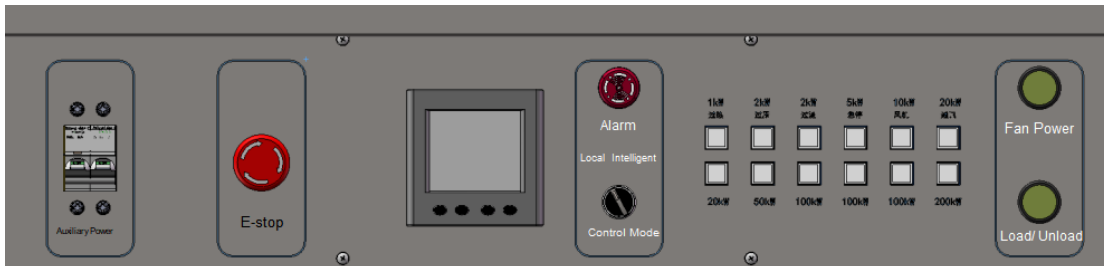

Control panel

9 After-sale Service

- (1). Warranty period is one year.
- (2). If required, technicians will be sent to help customer install, debug or repair the machine by the user's cost.
- (3). Customer has the right of technical consulting service for free forever.